



**MACERATING
FLO**

Innovation For A Better Flow

MF600R7

Macerating Toilet System

MACERATOR PUMP

FEATURES :

- 30 feet Max. Vertical Discharge
- 260 feet Max. Horizontal Discharge
- 3 Versatile Water Inlets
- 1 ½" Dual Use Vent Pipe
- Sewage Outlet With Built-in Check Valve

SPECIFICATIONS :

- **Dimension:** 17 ⁵/₁₆"L * 11 ⁷/₁₆"H * 7 ¹/₁₆"W
- **Power Factor:** 0.85
- **Insulation Class:** 155(F)
- **Speed:** 3450 RPM
- **Power Consumption:** 600 W
- **Supply Voltage:** 110V-60Hz
- **Enclosure Class:** IP 55
- **Max. Flow:** 130L/min
- **Start Level:** 65mm
- **Stop Level:** 35mm
- **Cable Length:** 39 ³/₈"
- **Amperage Draw:** 6A



TWO-PIECE TOILET

FEATURES :

- Rear Discharge Two-Piece Toilet
- Chair-Height (17 ⁵/₈")
- Tornado Rimless Flushing
- 18 ½" Comfortable Elongated Bowl
- Left-Handed Flush Lever

SPECIFICATIONS :

- **N.W:** 100.4 LB
- **Dimension:** 27"L * 31 ¹/₄"H * 15 ³/₄"W
- **Trap Type:** P-trap
- **Flush Type:** Rimless Flush
- **Flush Rate:** 1.28GPF
- **Waste Outlet:** Wall
- **Seat Shape:** Elongated
- **Installation Type:** Floor Mounted
- **Quality Assurance:** Limited 2-Year

PACKAGE INCLUDED :



Toilet Bowl



Floor Mounting Kit



Extension Pipes



Water Tank
(Fill Valve And Flapper Kit
Pre-installed)



Tank-To-Bowl Gasket

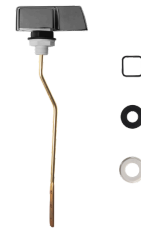

Flush Lever



Toilet Seat



Seat Mounting Kit



Macerator Pump



Pump Fittings



Adapter



	Pump	Bowl	Water Tank	Toilet Seat	Extension Pipes
Material	Stainless Steel, Polypropylene	Ceramic	Ceramic	Ceramic	Polypropylene
Color	White	White	White	White	White
Weight	14.3 LB	61.1 LB	31.3 LB	4.2 LB	2.3 LB

DIMENSIONAL DIAGRAM :

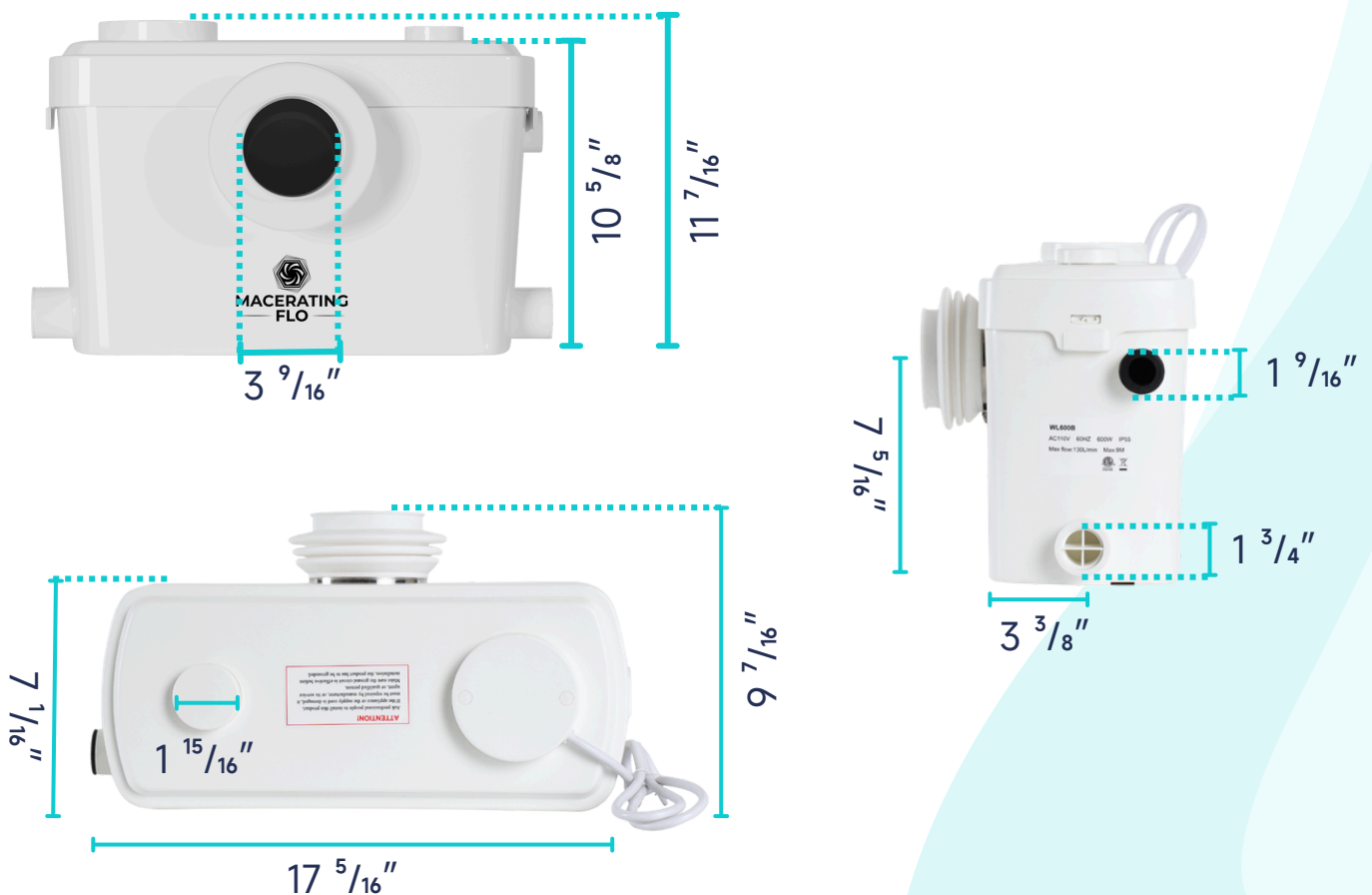



DIMENSIONAL DIAGRAM :

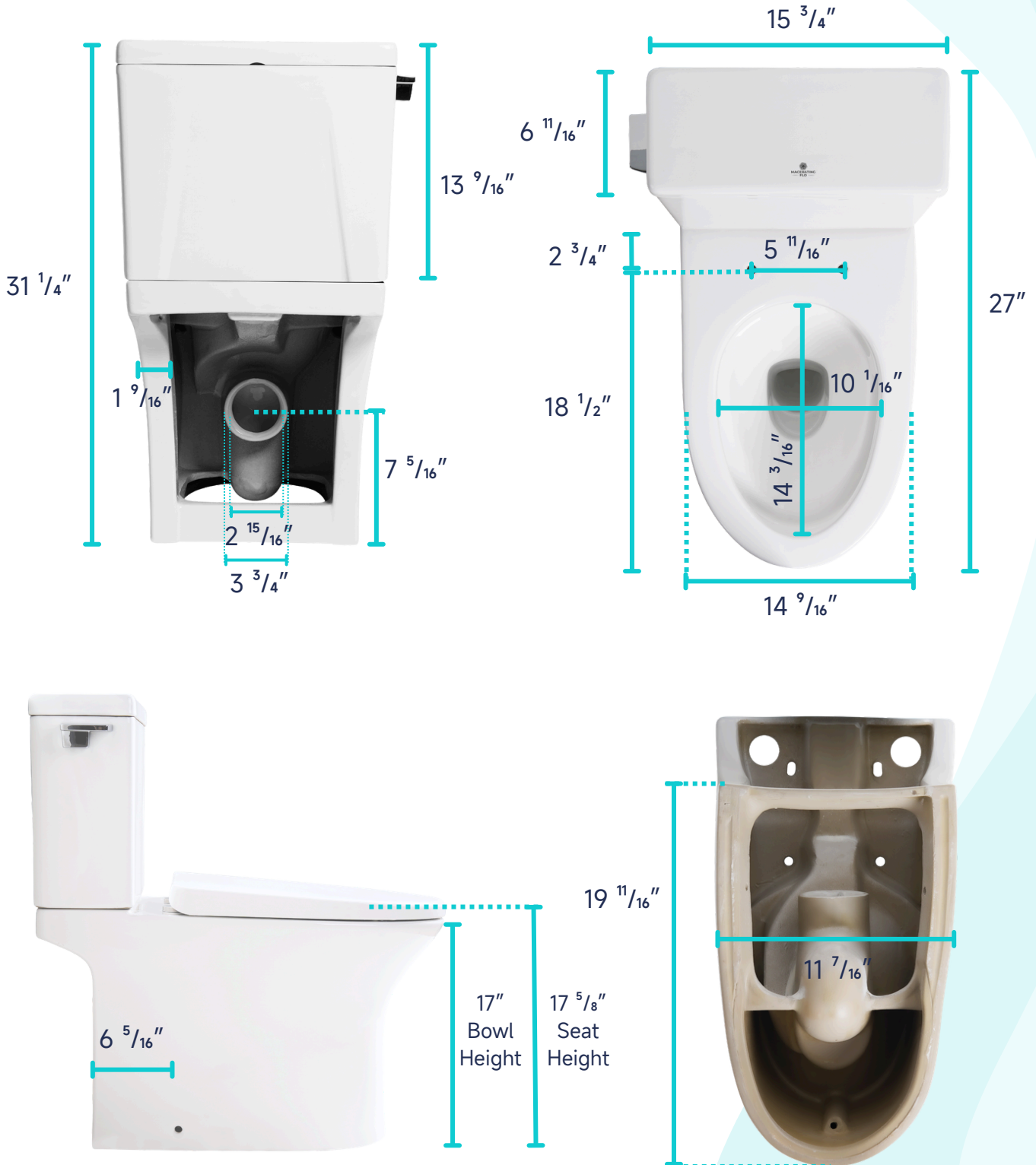



**MACERATING
FLO**

Innovation For A Better Flow

DIMENSIONAL DIAGRAM :

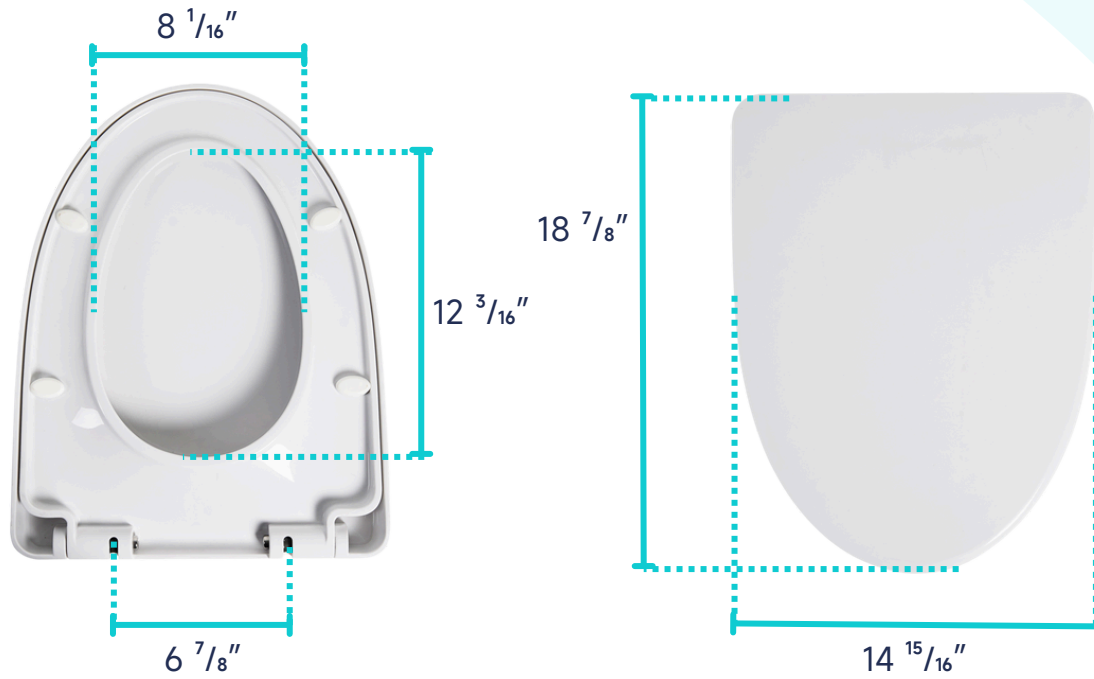

ABOUT WATER INLETS:





**MACERATING
FLO**

Innovation For A Better Flow

DIMENSIONAL DIAGRAM :

PUMP FITTINGS:

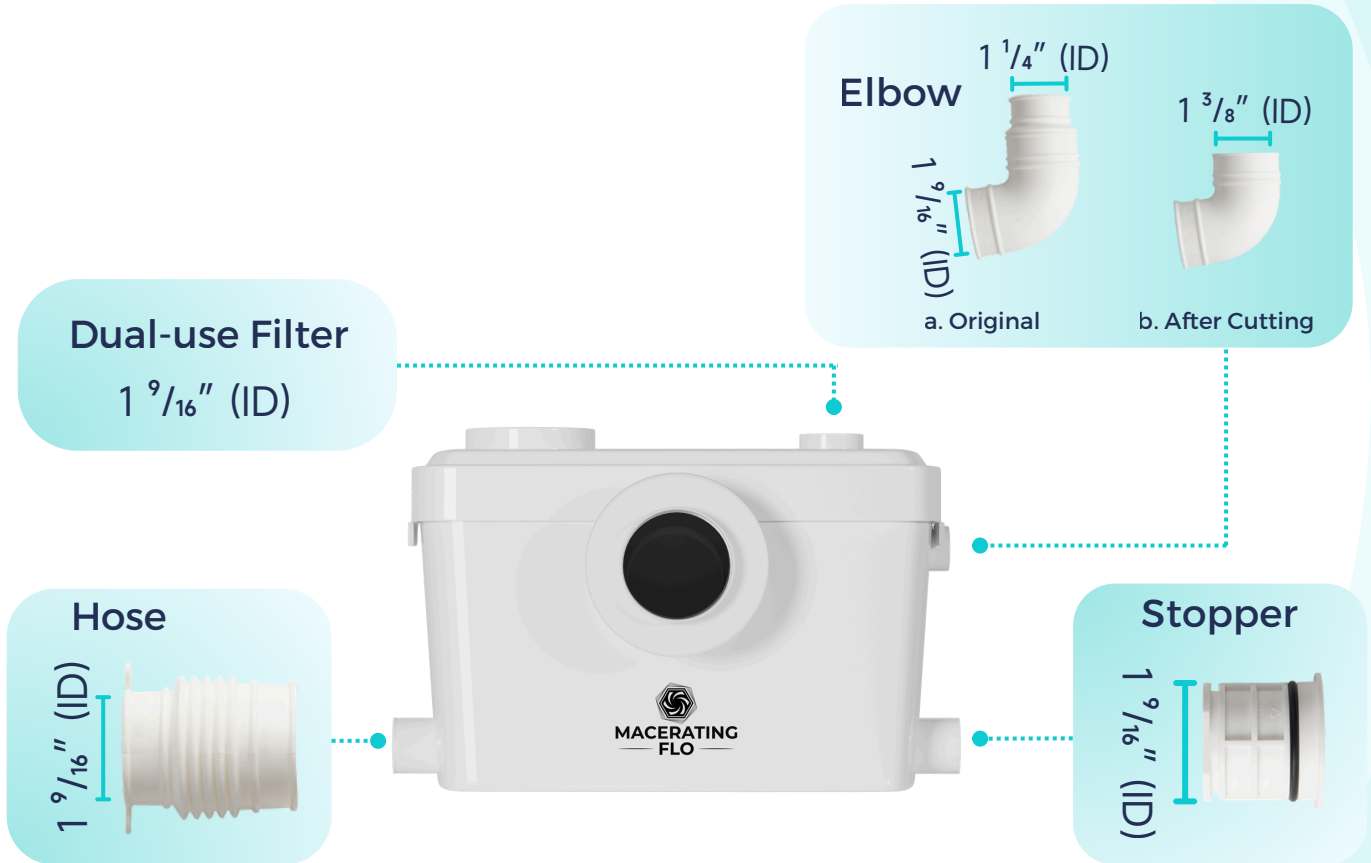

PIPE SIZE COMPATIBILITY

Name	Image	Originally Fits	After Cutting
Elbow		NPS 1" Pipe	NPS 1 1/4" Pipe
Flexible Hose		NPS 1" or 1 1/4" Pipe	/

DIMENSIONAL DIAGRAM :

NOTE

- 1" Pipe: Nominal Pipe Size 1", DN 25, AVG. OD 1.315"
- 1 1/4" Pipe: Nominal Pipe Size 1 1/4", DN 32, AVG. OD 1.660"
- To connect to a 1 1/2" pipe, you will need a flexible PVC coupling.
If you need any further assistance, please feel free to contact us at cs@maceratingflo.com.

EXTENSION PIPES:

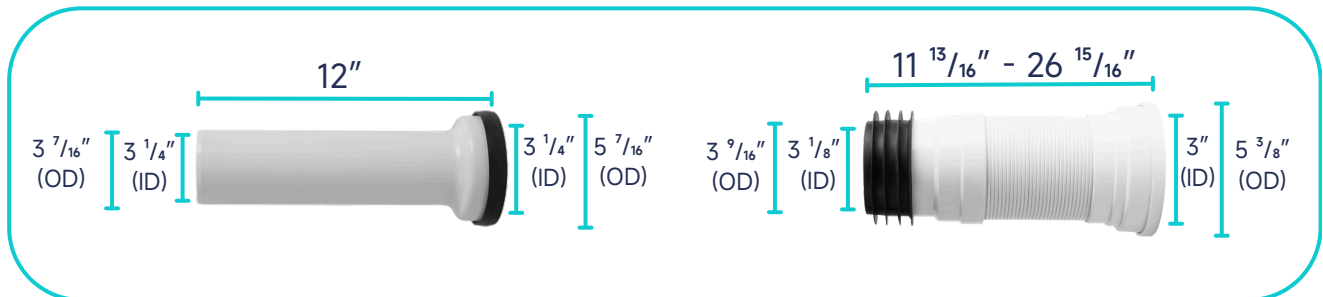

WATER TANK CONNECTION KIT:

